

Eighth
Edition

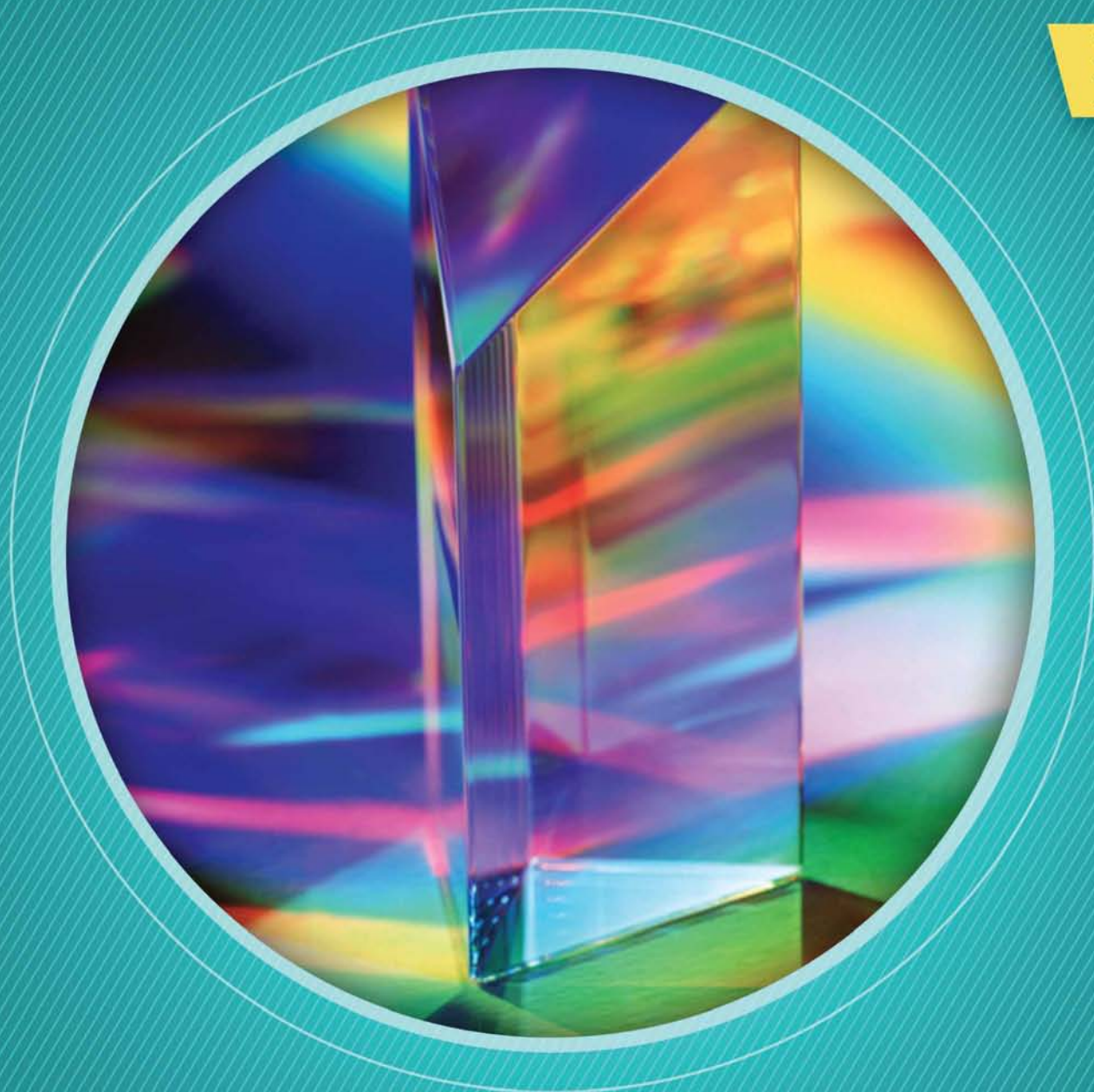

Physics

LABORATORY EXPERIMENTS

Jerry D. Wilson Cecilia A. Hernández-Hall

Metric Prefixes

Multiple		Name	Abbreviation
1,000,000,000,000,000,000	10^{18}	exa	E
1,000,000,000,000,000	10^{15}	peta	P
1,000,000,000,000	10^{12}	tera	T
1,000,000,000	10^9	giga	G
1,000,000	10^6	mega	M
1,000	10^3	kilo	k
100	10^2	hecto	h
10	10^1	deka	da
1	1	—	—
0.1	10^{-1}	deci	d
0.01	10^{-2}	centi	c
0.001	10^{-3}	milli	m
0.000001	10^{-6}	micro	μ
0.000000001	10^{-9}	nano	n
0.000000000001	10^{-12}	pico	p
0.000000000000001	10^{-15}	femto	f
0.00000000000000001	10^{-18}	atto	a

Physical Constants

Acceleration due to gravity	g	$9.8 \text{ m/s}^2 = 980 \text{ cm/s}^2 = 32.2 \text{ ft/s}^2$
Universal gravitational constant	G	$6.67 \times 10^{-11} \frac{\text{N}\cdot\text{m}^2}{\text{kg}^2}$
Electron charge	e	$1.60 \times 10^{-19} \text{ C}$
Speed of light	c	$3.0 \times 10^8 \text{ m/s} = 3.0 \times 10^{10} \text{ cm/s}$ $= 1.86 \times 10^5 \text{ mi/s}$
Boltzmann's constant	k	$1.38 \times 10^{-23} \text{ J/K}$
Planck's constant	h	$6.63 \times 10^{-34} \text{ J}\cdot\text{s} = 4.14 \times 10^{-15} \text{ eV}\cdot\text{s}$
	\hbar	$\hbar/2\pi = 1.05 \times 10^{-34} \text{ J}\cdot\text{s} = 6.58 \times 10^{-16} \text{ eV}\cdot\text{s}$
Electron rest mass	m_e	$9.11 \times 10^{-31} \text{ kg} = 5.49 \times 10^{-4} \text{ u} \leftrightarrow 0.511 \text{ MeV}$
Proton rest mass	m_p	$1.673 \times 10^{-27} \text{ kg} = 1.0078 \text{ u} \leftrightarrow 938.3 \text{ MeV}$
Neutron rest mass	m_n	$1.675 \times 10^{-27} \text{ kg} = 1.00867 \text{ u} \leftrightarrow 939.3 \text{ MeV}$
Coulomb's law constant	k	$1/4\pi\epsilon_0 = 9.0 \times 10^9 \text{ N}\cdot\text{m}^2/\text{C}^2$
Permittivity of free space	ϵ_0	$8.85 \times 10^{-12} \text{ C}^2/\text{N}\cdot\text{m}^2$
Permeability of free space	μ_0	$4\pi \times 10^{-7} = 1.26 \times 10^{-6} \text{ T}\cdot\text{M/A}$
Astronomical and Earth data		
Radius of the Earth		
equatorial		$6.378 \times 10^6 \text{ m} = 3963 \text{ mi}$
polar		$6.357 \times 10^6 \text{ m} = 3950 \text{ mi}$
average		$6.4 \times 10^3 \text{ km}$ (for general calculations)
Mass of the Earth		
the Moon		$7.4 \times 10^{22} \text{ kg} \approx \frac{1}{81}$ mass of Earth
the Sun		$2.0 \times 10^{30} \text{ kg}$
Average distance of the Earth		
from the Sun		$1.5 \times 10^8 \text{ km} = 93 \times 10^6 \text{ mi}$
Average distance of the Moon		
from the Earth		$3.8 \times 10^5 \text{ km} = 2.4 \times 10^5 \text{ mi}$
Diameter of the Moon		
		$3500 \text{ km} \approx 2160 \text{ mi}$
Diameter of the Sun		
		$1.4 \times 10^6 \text{ km} \approx 864,000 \text{ mi}$

PHYSICS LABORATORY EXPERIMENTS

E i g h t h E d i t i o n

PHYSICS LABORATORY EXPERIMENTS

E i g h t h E d i t i o n

JERRY D. WILSON

Lander University

**CECILIA A.
HERNÁNDEZ-HALL**

American River College



Australia • Brazil • Mexico • Singapore • United Kingdom • United States

This is an electronic version of the print textbook. Due to electronic rights restrictions, some third party content may be suppressed. Editorial review has deemed that any suppressed content does not materially affect the overall learning experience. The publisher reserves the right to remove content from this title at any time if subsequent rights restrictions require it. For valuable information on pricing, previous editions, changes to current editions, and alternate formats, please visit www.cengage.com/highered to search by ISBN#, author, title, or keyword for materials in your areas of interest.

Physics Laboratory Experiments,
Eighth Edition
Jerry D. Wilson and Cecilia A. Hernández-Hall

Product Director: Mary Finch
Senior Product Manager: Charles Hartford
Content Developer: Alyssa White
Associate Content Developer: Brandi Kirksey &
Brendan Killion
Product Assistant: Christopher Robinson
Media Developer: Rebecca Berardy Schwartz
Senior Marketing Manager: Janet del Mundo
IP Analyst: Christine Myaskovsky
IP Project Manager: John Sarantakis
Manufacturing Planner: Sandra Milewski
Art and Cover Direction, Production
Management, and Composition:
PreMediaGlobal
Cover Image: © Pete Saloutos/CORBIS

© 2015, 2010, 2005 Cengage Learning

WCN: 02-200-203

ALL RIGHTS RESERVED. No part of this work covered by the copyright herein may be reproduced, transmitted, stored, or used in any form or by any means graphic, electronic, or mechanical, including but not limited to photocopying, recording, scanning, digitizing, taping, Web distribution, information networks, or information storage and retrieval systems, except as permitted under Section 107 or 108 of the 1976 United States Copyright Act, without the prior written permission of the publisher.

For product information and technology assistance, contact us at
Cengage Learning Customer & Sales Support, 1-800-354-9706

For permission to use material from this text or product,
submit all requests online at www.cengage.com/permissions
Further permissions questions can be e-mailed to
permissionrequest@cengage.com

Library of Congress Control Number: 2013957293

ISBN-13: 978-1-285-73856-7

ISBN-10: 1-285-73856-X

Cengage Learning

200 First Stamford Place, 4th Floor
Stamford, CT 06902
USA

Cengage Learning is a leading provider of customized learning solutions with office locations around the globe, including Singapore, the United Kingdom, Australia, Mexico, Brazil, and Japan. Locate your local office at www.cengage.com/global.

Cengage Learning products are represented in Canada by Nelson Education, Ltd.

To learn more about Cengage Learning Solutions, visit www.cengage.com

Purchase any of our products at your local college store or at our preferred online store www.cengagebrain.com

“What is the meaning of it all, Mr. Holmes?”

“Ah, I have no data. I cannot tell,” he said

Arthur Conan Doyle (1859–1930), *The Adventures of Sherlock Holmes*, 1892

Contents

[Key: GL (Guided Learning), TI (Traditional Instruction), and CI (Computer Instruction), GL is associated only with TI experiments. See Preface.]

Preface	xi
Introduction	xv
Why We Make Experimental Measurements	xv
General Laboratory Procedures	xv

Experiments in the bound volume

1. The Scientific Method and Thought	1
2. Experimental Uncertainty (Error) and Data Analysis	11
3. Measurement Instruments (Mass, Volume, and Density)	31
4. (GL) Simple Pendulum Parameters (Angle, Mass, Length, and Damping)	45
5. (TI-GL/CI) Uniformly Accelerated Motion: Measurement of g	57
6. The Addition and Resolution of Vectors: The Force Table	75
7. (TI-GL/CI) Newton's Second Law: The Atwood Machine	85
8. (TI/CI) Conservation of Linear Momentum	105
9. (GL) Projectile Motion: The Ballistic Pendulum	129
10. Centripetal Force	143
11. (TI/CI) Friction	153
12. (GL) Work and Energy	173
13. Potential Energy of a Spring	187
14. (GL) Torques, Equilibrium, and Center of Gravity	195
15. (GL) Simple Machines: Mechanical Advantage	209
16. (TI/CI) Simple Harmonic Motion	225
17. Standing Waves in a String	245
18. Temperature and Thermometer Calibration	255
19. The Thermal Coefficient of Linear Expansion	261
20. Specific Heats of Metals	271

21. Archimedes' Principle: Buoyancy and Density	281
22. Fields and Equipotentials	293
23. (TI/CI) Ohm's Law	303
24. The Measurement of Resistance: Ammeter-Voltmeter Methods and Wheatstone Bridge Method	321
25. The Temperature Dependence of Resistance	335
26. (TI/CI) Resistances in Series and Parallel	347
27. Joule Heat	371
28. The RC Time Constant (Manual Timing)	379
29. (TI/CI) The RC Time Constant (Electronic Timing)	387
30. Reflection and Refraction	405
31. Spherical Mirrors and Lenses	415
32. (TI) Polarized Light (CI) Malus's Law	431
33. The Prism Spectrometer: Dispersion and the Index of Refraction	451
34. Line Spectra and the Rydberg Constant	459
35. (TI) The Transmission Diffraction Grating: Measuring the Wavelengths of Light (CI) Single-Slit and Double-Slit Diffraction	469
36. Detection of Nuclear Radiation: The Geiger Counter	493
37. Radioactive Half-Life	503
38. The Absorption of Nuclear Radiation	511
Appendix A Material Properties	523
Appendix B Mathematical and Physical Constants	529
Appendix C Absolute Deviation and Mean Absolute Deviation	532
Appendix D Standard Deviation and Method of Least Squares	533
Appendix E Graphing Exponential Functions	535

Experiments available in customized orders

39. (TI/CI) Rotational Motion and Moment of Inertia
40. Conservation of Angular Momentum and Energy: The Ballistic Pendulum
41. Elasticity: Young's Modulus
42. Air Column Resonance: The Speed of Sound in Air
43. (TI) Latent Heats: Heats of Fusion and Vaporization of Water (CI) Latent Heat of Fusion Water

44. Newton's Law of Cooling: The Time Constant of a Thermometer
45. The Potentiometer: emf and Terminal Voltage
46. The Voltmeter and Ammeter
47. Resistivity
48. Multiloop Circuits: Kirchhoff's Rules
49. The Earth's Magnetic Field
50. Introduction to the Oscilloscope
51. (TI/CI) Phase Measurements and Resonance in AC Circuits
52. (TI/CI) Electromagnetic Induction
53. The Mass of an Electron: e/m Measurement

Preface

Physics Laboratory Experiments was written for students of introductory physics—in fact, it was originally written at the request of students. The main purpose of laboratory experiments is to augment and supplement the learning and understanding of basic physical principles, while introducing laboratory procedures, techniques, and equipment.

The eighth edition of *Physics Laboratory Experiments* has 38 experiments, with 15 additional customized experiments. All 53 experiments are available for customization at TextChoice.com. (See Experiments Available for Customized Publishing.) This provides an ample number of experiments to choose from for a two-semester or three-quarter physics course. Those features that proved effective in previous editions have been retained, along with **Guided Learning (GL)**. Basically, GL is an effort to supplement the “cookbook” style. For better learning and understanding, an Experimental Planning section gives a brief introduction and guides the students through the basics of an experiment by a series of related questions that they answer.

The GL Experimental Planning is limited to selected Traditional Instruction (TI) experiments, about which students should have some knowledge. These are labeled **GL** in the table of contents.

Pre-Lab Demos

An added feature to the eighth edition of *Physics Laboratory Experiments* is a set of pre-lab demonstrations. The purpose of these demos is to “break the ice,” so to speak. Students often come to the laboratory lacking enthusiasm. If something attention-getting (a demo) is presented initially that is related to the experiment or associated class material, interest is aroused. This being done, the instructor can lead into the current lab experiment. Abbreviated demo descriptions are given at the beginning of the experiments.

A complete list of demonstrations (descriptions and explanations) is available online, along with the Instructor’s Resource Manual.

Traditional Instruction (TI) and Computerized Instruction (CI)

The use of computerized instruction and equipment has become increasingly popular in introductory physics laboratories. To accommodate this, 10 experiments have both TI and CI sections, the latter of which describes an experiment using computerized equipment.* The TI and CI components generally treat the same principles but from different perspectives. These experiments give the instructor the option of doing the TI experiment, the CI experiment, or *both*.

It is suggested that in some instances students do the hands-on TI experiment first, so as to gain a basic knowledge of what is being measured. It is here that the physical parameters of the experiment are clearly associated with principles and results. Once students have this type acquaintance with experimental concepts, they can better perform the CI experiment (or view it as a demonstration if limited CI equipment is available).

The student can then better understand the computer procedure and analysis of electronic recorded data. This is particularly important in graphical analysis, where graphs are immediately plotted on monitor screens without a firm understanding of the parameters involved.

Experiments Available for Customized Publishing

These provide a handy, customizable option—a way for instructors to build their own lab manual that fits the need of their specific courses. All 38 experiments available in the printed manual, and an additional 15 experiments that include four TI–CI experiments, are available through TextChoice.

*Four more TI/CI experiments are available in the customized listing in the Table of Contents.

Cengage Learning's digital library, TextChoice, enables you to build your custom version of *Physics Laboratory Experiments* from scratch. You may pick and choose the content you want to be included in your lab manual and even add your own original materials creating a unique, all in one learning solution. Visit www.textchoice.com to start building your book today.

A list of the additional experiments can be seen in the Table of Contents.

Organization of the Eighth Edition

Both the TI and CI experiments are generally organized into the following sections:

- (In some instances, **TI Experimental Planning for Guided Learning**)
- Advance Study Assignment
- Introduction and Objectives
- Equipment Needed
- Theory
- Experimental Procedure
- Laboratory Report
- Post-lab Questions

Features include:

Laboratory Safety. Safety is continually stressed and highlighted in the manual. This critical issue is expanded upon in the Introduction to the manual.

Advance Study Assignments. Students often come to the laboratory unprepared, even though they should have read the experiment before the lab period to familiarize themselves with it. To address this problem, an Advance Study Assignment precedes each experiment. The assignment consists of a set of questions drawn from the Theory and Experimental Procedures sections of the experiment. To answer the questions, students must read the experiment before the lab period; consequently, they will be better prepared. It is recommended that the Advance Study Assignment be collected at the beginning of the laboratory period.

Example Calculations. In the Theory section of some experiments, sample calculations that involve the equations and mathematics used in

the experiment have been included where appropriate. These demonstrate to the student how experimental data are applied.

Illustrations. Over 200 photographs and diagrams illustrate experimental procedures, equipment, and computer programs. To allow for variation in laboratory equipment, different types of equipment that can be used are often illustrated.

Laboratory Reports. Because a standardized format for Laboratory Reports greatly facilitates grading by the instructor, a Laboratory Report is provided for both TI and CI experiments. These reports provide a place for recording data, calculations, experimental results, and analyses. Only the Laboratory Report and post-lab Questions that follow it need to be submitted for grading. The Laboratory Report tables are organized for easy data recording and analysis. Students are reminded to include the units of measurement.

Maximum Application of Available Equipment. Laboratory equipment at many institutions is limited, and often only standard equipment, purchased from scientific suppliers, is available. The TI experimental procedures in this manual are described for different types of common laboratory apparatus, thus maximizing the application of the manual.

Instructor's Resource Manual

The Instructor's Resource Manual is a special feature and resource for the instructor. It is available online on the instructor Web site prepared to accompany the eighth edition of *Physics Laboratory Experiments*. To view a sampling of instructor materials, go to www.cengage.com/Physics, and click on the link for Algebra and Trigonometry Based Lab Manuals. For the eighth edition of *Physics Laboratory Experiments*, clicking the About This Product link will allow you to view online resources including the Instructor's Resource Manual. You may contact your Cengage representative if you need new access to this password-protected material.

Professor Fred B. Otto, previously of the Maine Maritime Academy, who has over 20 years of teaching and laboratory experience, has revised this manual. He retained the general format of the previous edition. For each experiment, there are (1) Comments and Hints, (2) Answers to post-Experiment Questions, and (3) Post-lab Quiz Questions [completion and multiple-choice (with answers), and essay]. The Instructor's Resource Manual also includes laboratory safety references, lists of scientific equipment suppliers and physics software suppliers, and graph paper copy masters.

Of course, the publication of this manual would not have been possible without a great deal of help. The in-depth review of TI experiments, along with independent testing of new experiments and demonstrations, by Professor Paige Ouzts of Lander University, resulted in many helpful suggestions and recommendations. Professor Hernandez and I would like to thank the people at PASCO—in particular, Paul A. Stokstad, and Jon and Ann Hanks—for their

support. We are grateful to Charlie Hartford, Senior Product Manager; Alyssa White, Content Developer; Brandi Kirksey, Associate Content Developer; and Christopher Robinson, Product Assistant.

We both hope that you will find the eighth edition of *Physics Laboratory Experiments* helpful, educational, and enjoyable. And we urge anyone—student or instructor—to pass on to us any suggestions that you might have for improvement.

Jerry D. Wilson
Emeritus Professor of Physics
Lander University
Greenwood, South Carolina
jwilson@greenwood.net

Cecilia A. Hernández-Hall
Professor of Physics
American River College
Sacramento, California
hernanc@arc.losrios.edu

Introduction

WHY WE MAKE EXPERIMENTAL MEASUREMENTS

When you can measure what you are speaking about and express it in numbers, you know something about it; but when you cannot measure it, when you cannot express it in numbers, your knowledge is of a meager and unsatisfactory kind.

LORD KELVIN
(1824–1907)

As Lord Kelvin so aptly expressed, we measure things to know something about them—so that we can describe objects and understand phenomena. Experimental measurement is the cornerstone of the *scientific method*, which holds that no theory or model of nature is tenable unless the results it predicts are in accord with experiment. More on this in Experiment 1: The Scientific Method and Thought.

The main purpose of an introductory physics laboratory is to provide “hands-on” experiences of various physical principles. In so doing, one becomes familiar with laboratory equipment, procedures, and the scientific method.

In general, the theory of a physical principle will be presented in an experiment, and the predicted results will be tested by experimental measurements. Of course, these well-known principles have been tested many times before, and there are accepted values for certain physical quantities. Basically, you will be comparing your experimentally measured values to accepted theoretical or measured values. Even so, you will experience the excitement of the scientific method. Imagine that you are the first person to perform an experiment to test a scientific theory.

GENERAL LABORATORY PROCEDURES

Safety

The most important thing in the laboratory is your safety and that of others. Experiments are

designed to be done safely, but proper caution should always be exercised.

A potential danger comes from a lack of knowledge of the equipment and procedures. Upon entering the physics lab at the beginning of the lab period, you will probably find the equipment for an experiment on the laboratory table. Restrain your curiosity, and do not play with the equipment. You may hurt yourself and/or the equipment. A good general rule is:

Do not touch or turn on laboratory equipment until it has been explained and permission has been given by the instructor.

Also, certain items used in various experiments can be particularly dangerous, for example, hot objects, electricity, mercury lamps, and radioactive sources. In some instances, such as with hot objects and electricity, basic common sense and knowledge are required.

However, in other instances, such as with mercury lamps and radioactive sources, you may not be aware of the possible dangers. Mercury lamps may emit ultraviolet radiation that can be harmful to your eyes. Consequently, some sources need to be properly shielded. Some radioactive sources are solids and are encapsulated to prevent contact. Others are in liquid form and are transferred during an experiment, so there is a danger of spillage. Proper handling is therefore important.

In general, necessary precautions will be given in the experiment descriptions. *Note them well.* When you see the arrow symbol in the margin as illustrated here, you should take extra care to follow the procedure carefully and adhere to the precautions described in the text. As pointed out earlier, experiments are designed to be done safely. Yet a common kitchen match can be dangerous if used improperly. Another good rule for the laboratory is:

If you have any questions about the safety of a procedure, ask your instructor before doing it.

The physics lab is a place to learn and practice safety.

Equipment Care

The equipment provided for the laboratory experiment is often expensive and, in some instances, quite delicate. If used improperly, certain pieces of apparatus can be damaged. The general rules given above concerning personal safety also apply to equipment care.

Even after familiarizing oneself with the equipment, it is often advisable or required to have an experimental setup checked and approved by the instructor before putting it into operation. This is particularly true for electrical experiments. Applying power to improperly wired circuits can cause serious damage to meters and other pieces of apparatus.

If a piece of equipment is broken or does not function properly, it should be reported to the

laboratory instructor. Also, after you complete an experiment, the experimental setup should be disassembled and left neatly as found, unless you are otherwise instructed.

If you accidentally break some equipment or the equipment stops working properly during an experiment, *report it to your instructor*. Otherwise, the next time the equipment is used, a great deal of time may be wasted trying to get good results.

Laboratory Reports

A Laboratory Report form is provided for each experiment in which experimental data are recorded. This should be done *neatly*. Calculations of experimental results should be included. Remember, the neatness, organization, and explanations of your measurements and calculations in the Laboratory Report represent the quality of your work.

PHYSICS LABORATORY EXPERIMENTS

E i g h t h E d i t i o n

E X P E R I M E N T 1

The Scientific Method and Thought

TI *Advance Study Assignment*

Read the experiment and answer the following questions.

1. What are the elements of the scientific method?
2. How is a hypothesis tested?
3. When does a theory become a law?
4. What happens when a scientific law is broken?

(continued)

5. We use our senses to make observations. Comment on their limitations and reliability.
6. Is scientific thinking only applicable to sciences such as physics or chemistry? Explain.



PRE-LAB DEMONSTRATION | Skewed Balloon (and it doesn't burst)

The purpose of this demonstration is to get you thinking and to apply the scientific method (or scientific thinking). A wooden (bamboo) skewer is pushed completely through an inflated balloon without it collapsing (● Fig. D1). How is this possible?



Figure D1 Skewed Balloon

EXPERIMENT 1

The Scientific Method and Thought

“It is a capital mistake to theorize before one has data. Insensibly one begins to twist the facts to suit the theories, instead of the theories to suit the facts.”

ARTHUR CONAN DOYLE (1859–1930), *THE ADVENTURES OF SHERLOCK HOLMES*

INTRODUCTION AND OBJECTIVES

The physics laboratory is a learning place—a place to observe and analyze. To investigate the physical world, scientists use what is known as the **scientific method**, which states: *No hypothesis, theory, or law of nature is valid unless its predictions are in agreement with experimental results (quantitative measurements).*

In this experiment, you will examine several situations using the scientific method so as to become familiar with its aspects.

After performing the experiment and analyzing the results, you should be able to do the following:

1. Know how to formulate a hypothesis.
2. Explain how a hypothesis is tested.
3. Distinguish between a theory and a law.
4. Describe how instruments can aid in measurements and perceptions.

THEORY

A general breakdown of the elements of the scientific method is as follows:

- **Observation.** Scientists are curious folks. This curiosity leads them to ask questions about the observed occurrences in the world around them.
- **Hypothesis.** Scientists give a possible explanation of some observation(s), in other words, a tentative answer or an educated guess.
- **Experiments.** The hypothesis is tested under controlled conditions to see if the results confirm the hypothetical assumptions and can be duplicated.
- **Theory.** If a hypothesis passes enough experimental tests and generates new predictions that also prove correct, it takes on the status of a theory—a well-tested explanation of observed physical phenomena.
- **Law.** If a theory has withstood the test of many valid experiments with great regularity, that theory may be accepted by scientists as a law. This is a concise statement in words or mathematical equations that describes a fundamental relationship of nature. Scientific laws are somewhat analogous to legal laws, which may be repealed or modified if inconsistencies are later discovered. Unlike legal laws, however, scientific laws are not meant to regulate but to describe.

Galileo (1564–1642) is said to be the father of the scientific method. He was one of the first to use experimental results to test hypotheses. As you will probably study in class, legend has it that one of his experiments was to drop cannon balls of different weights from the Leaning Tower of Pisa. This was to investigate his hypothesis that the speed of a falling object did not depend on weight or mass. The cannon balls of different weights dropped simultaneously from the same height hit the ground together, giving experimental credence to Galileo's hypothesis.

Of course, you will not be using the scientific method to make new discoveries in the laboratory. For the most part, you will be investigating established theories and laws so as to become familiar with experimental procedures and analysis. However, in this experiment, we'll have some fun in focusing on the first three elements of the scientific method: observation, hypothesis, and experiment (testing).

And then there is perception. Our senses have limitations. For example, the unaided eye cannot see the majority of stars and galaxies. We cannot immediately distinguish the visible stars of our galaxy from the planets of our solar system, all of which appear as points of light. (The planets, however, move relative to the stars. The word *planet* comes from the Greek word meaning “wanderer.”)

Not only do our senses have limitations, but they can also be deceived and may provide false information. For

example, perceived sight information may not always be a true representation of the facts because the brain can be fooled. Optical illusions are examples of this; to demonstrate, some of the classic illusions will be examined. An optical illusion may be defined as a visual perception of a real object in such a way as to misinterpret its actual nature. Some people may be quite convinced that what they see in such drawings actually exists as they perceive it.

However, in experiments, one must observe carefully and objectively and guard against making such errors. In general, such deceptions may be eliminated by using instruments.

Finally, a word about scientific thought or scientific thinking. Using the scientific method is in essence

practicing scientific thinking—observing, reasoning, reaching logical conclusions, and so forth. However, this is not restricted just to science. Methods and principles of scientific thinking are used in everyday life and in the study of other disciplines—history, philosophy, literature, economics, and so on. This is sometimes called *critical thinking* and is used to obtain reliable answers to questions and solutions to problems by critically analyzing them.

Have you ever seen a magician do a magic trick and tried to figure out and explain what actually happened (or didn't happen)? If so, you were trying to do so by applying scientific or critical thinking, which is based on logic and experience.

EQUIPMENT NEEDED

- Crisp, unfolded dollar bill (larger denominations work too).
- Meterstick and ruler (with centimeter scale).
- Four paper muffin cups. (Paper coffee filters, as used in coffee makers, may also be used.)
- Optical illusions (in experiment ● Fig. 1.2).

INVESTIGATIONS

A. Dollar Drop

Observation. Hold your hand with the thumb and forefinger about 1.3 cm (0.5 in.) apart. The thumb and forefinger should be horizontal and parallel. The idea is to form a slot through which a dollar bill will be dropped. Have a lab partner hold the dollar bill vertically with the short side just even with the top of your fingers (see ● Fig. 1.1).

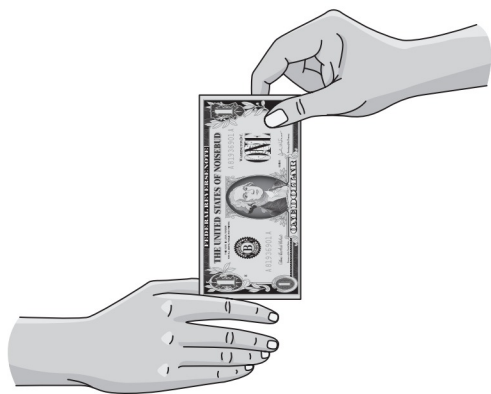

Figure 1.1 Have the bill held just right. See text for description.

Then, without telling you when it will be released, have the partner drop the bill; you try to catch it. (Dropping the bill yourself isn't cricket as you would be inadvertently aware of when it was released.) You may want to repeat this process several times, and also with your lab partner doing the catching and you the dropping. (If you are like most of us, you will not be able to catch the bill. This is sometimes used as a party joke—if you catch the bill, you can have it.)

Hypothesis. Why couldn't you catch the bill falling under the influence of gravity? Closing the fingers must be too slow; that

is, it involves a person's reaction time—the time it takes the muscles to react to the brain's signal and complete the task.

Experiment. So how does one measure the reaction time to prove this? There is no stop watch available, and even so, you have to use reaction times to start and stop the watch. Quantities are often measured by indirect means. This can be done by using a falling ruler. Repeat the dollar bill procedure with the ruler, and note the centimeter mark at the top of your fingers on catching it. (If you start with the zero end of the ruler downward, this is the length the ruler fell through your fingers during the reaction time.) Repeat three times with each lab partner and record the results in the Laboratory Report, and take the average of the set of measurements.

Analysis. The reaction time may be computed from the equation

$$d = \frac{1}{2}gt^2$$

This is the distance (d) an object falls when released from rest; t is the time it takes to fall that distance. Solve for t and, using the average ruler drop distance, compute an average reaction time. (The acceleration due to gravity $g = 9.8 \text{ m/s}^2$, and to be consistent, d must be in meters.) Record and answer the questions in the lab report.

B. Muffin Cup Drop

In section A, the falling ruler was assumed to be in free fall (only under the influence of gravity), and there was no consideration of air resistance. This is a good approximation over relatively short distances. However, in falling, air resistance occurs when an object collides with air molecules. Therefore, air resistance depends on an object's size and shape (which determines the area exposed to collisions). The more exposed surface area, the more collisions there will be with air molecules.

The air resistance builds up as a falling object gains speed. Then, when the downward weight force is balanced by the upward resistance force (a frictional force), the object falls at a constant rate that is called the *terminal velocity*.

Observation. Suppose Galileo had simultaneously dropped two cannon balls of identical size but of different masses (weights) from a high-altitude hot air balloon. In this case, it is observed that the heavier ball strikes the ground first.

Hypothesis. The balls have identical shapes, so the exposed areas to the air molecules are the same. The heavier ball must speed up ahead of the light ball to get the ground first, but they both experience the same acceleration due to gravity. The masses of the balls are different, so this must have something to do with it. What is the answer? Sometimes experiments are needed to formulate a hypothesis that will help clarify an observation.

Experiment. Let's try to recreate the observation in the lab. Hot air balloons and cannon balls are out, but we have paper muffin cups that fit nicely into the laboratory budget. The cups may be nested (put inside each other), which gives approximately the same size and shape in falling when one, two, or more nested cups are dropped. However, the masses are different. Does this have an effect?

- (a) Drop one cup from shoulder height (bottom side down) and notice that it simulates terminal velocity (falls at a constant rate).
- (b) Simultaneously drop a single cup and two nested cups from the same shoulder height. Does the number of cups (mass) make a difference?
- (c) Simultaneously drop the single cup from a 1 m height and the two nested cups from a greater height until a height is found for which both hit the floor at the same time. Note and measure the height at which the nested cups were released to accomplish this and record it in the Laboratory Report.
- (d) Repeat the procedure for three nested cups.

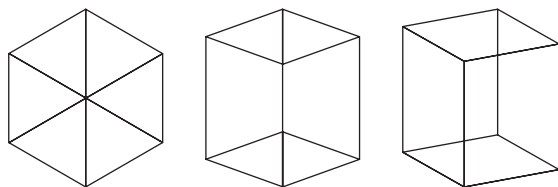

(a) Cubes which side up?

Analysis. When a falling object reaches terminal velocity, the downward gravitational force on the object ($F = mg$) is balanced by the upward force of air resistance that is proportional to the square of the speed, $f = kv^2$. Thus, a falling object can reach terminal velocity relatively quickly. This being the case, the distance of fall may be approximated by $d = vt$.*

Note that with $f = kv^2$, and since f and $F = mg$ are equal in magnitude at terminal velocity, we have $v = \sqrt{f/k} = \sqrt{F/k} = \sqrt{mg/k}$. The ratio of the distances of fall of two objects of different masses is then

$$\frac{d_2}{d_1} = \frac{v_2 t}{v_1 t} = \frac{v_2}{v_1} = \left(\frac{F_2}{F_1}\right) = \left(\frac{m_2}{m_1}\right)^{\frac{1}{2}} \quad (1.1)$$

- (1) Using the mass ratio of two cups to one, $m_2 = 2m_1$, compute the distance ratio (Eq. 1.1). Using $d_1 = 1$ m (as in the experiment), compute d_2 , the height at which two nested cups should be released to hit the floor simultaneously with the single cup. Record this in the Laboratory Report and compare with the experimental height.
- (2) Repeat the calculation for three (3) nested cups. Record in the Laboratory Report and answer the questions.

C. Perception: Can You Be Fooled?

Look at the optical illusions in Fig. 1.2 and answer the associated questions. You may use instruments if you like. (There is no need to record; the instructor will take your word for it.) See if you can explain why there is an illusion in each case.

* $d = vt$ is not strictly true because there is some initial acceleration. However, scientists often make assumptions in analyses to simplify and make understanding easier. If the assumption is too far afield, the results of the analysis will not agree with experimental data (which violates the scientific method).

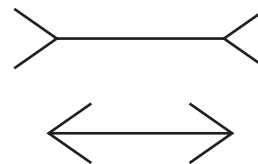

(b) Is the upper horizontal line longer?

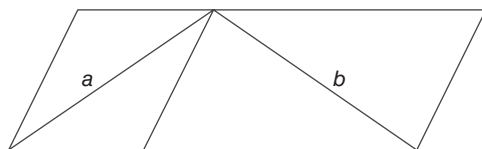

(c) Is the diagonal line *b* longer than the diagonal line *a*?

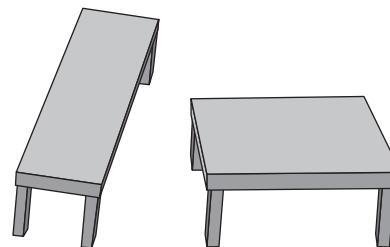

(d) Which table top is larger?

Figure 1.2 We can be fooled by what we see. Answer the questions under the drawings.

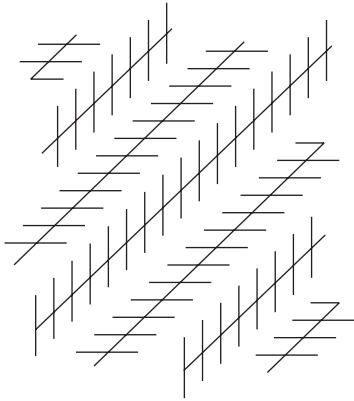

(e) Are the diagonal lines parallel?

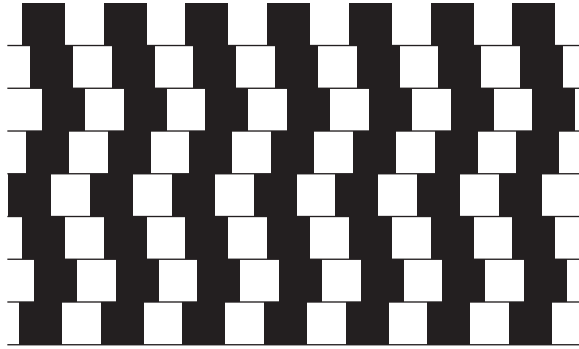

(f) Are the horizontal lines parallel or do they slope?

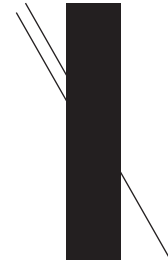

(g) With which of the upper lines does the line on the right connect?

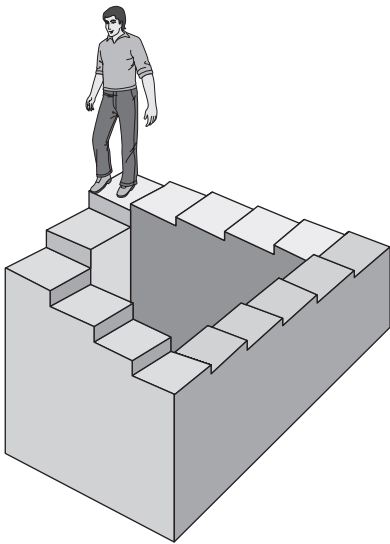

(h) Going down?

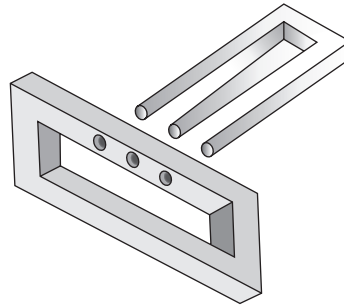

(i) Is something dimensionally wrong here?

Figure 1.2 We can be fooled by what we see. Answer the questions under the drawings. (Continued)

E X P E R I M E N T 1

The Scientific Method and Thought

T1 *Laboratory Report*

A. Dollar Drop

DATA TABLE 1

Purpose: To determine reaction time.

Distance of fall ()		
Average		

Calculations
(show work)

Reaction
time:

A. Data Table

- Measure the length of the dollar bill and compare with the ruler drop distance. What does this tell you?
- What would your reaction time have to be to catch the bill?

(continued)

EXPERIMENT 1 The Scientific Method and Thought

Laboratory Report

TI QUESTIONS

1. If you dropped the dollar bill (or ruler) yourself, how might this affect the reaction time?

2. Suppose three nested muffin cups and five nested cups were used in the experiment. From what height should the five cups be dropped to hit the floor together with the three cups dropped from a height 1 m? (Show calculations.)

3. Why is using instruments so important in taking experimental data, rather than using our senses directly?